

Slotted Set Screws

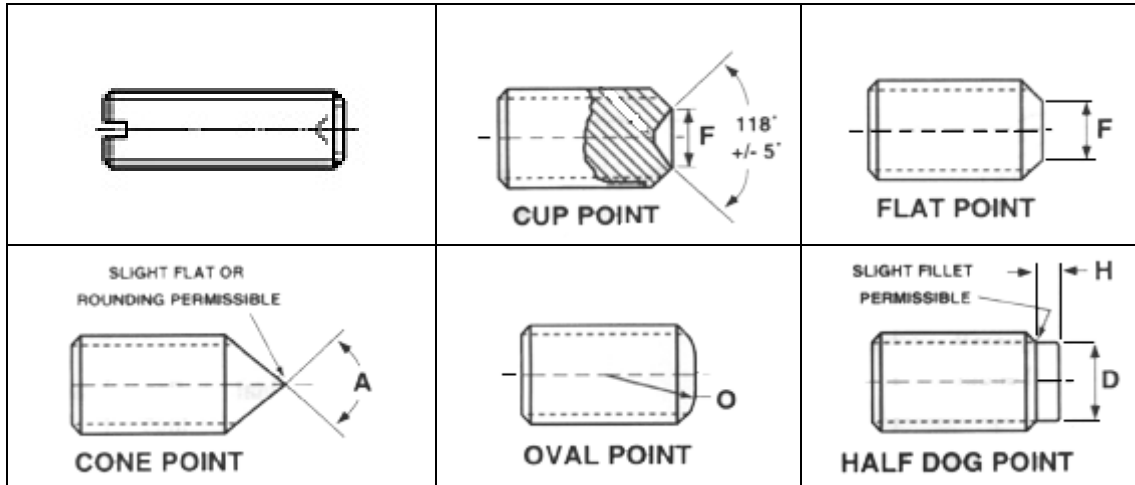

Cup Point (standard)	Alloy - SSC800-----	Stainless = SSC188-----
Flat Point	Alloy - SSFP800-----	Stainless = SSFP188-----
Cone Point	Alloy - SSCP800-----	Stainless = SSCP188-----
Oval Point	Alloy - SSOP800-----	Stainless = SSOP188-----
Half Dog Point	Alloy - SSHD800-----	Stainless = SSHD188-----
Full Dog Point	Alloy - SSFD800-----	Stainless = SSFD188-----

Class 3A Fit Alloy: Rockwell Hardness 38-43

Nominal Size	S	K	F		O	D		H	
	Hexagon Socket Size	Min Key Engagement	Cup & Flat Point Diameter		Oval Point Radius	Half Dog Point			
			Max	Min		Diameter		Length	
						Max	Min	Max	Min
4	0.050	0.070	0.061	0.051	0.084	0.075	0.070	0.030	0.026
5	1/16	0.080	0.067	0.057	0.094	0.083	0.078	0.033	0.027
6	1/16	0.080	0.074	0.064	0.104	0.092	0.087	0.038	0.032
8	5/64	0.090	0.087	0.076	0.123	0.109	0.103	0.043	0.037
10	3/32	0.100	0.102	0.088	0.142	0.127	0.120	0.049	0.041
1/4	1/8	0.125	0.132	0.118	0.188	0.156	0.149	0.067	0.059
5/16	5/32	0.156	0.172	0.156	0.234	0.203	0.195	0.082	0.074
3/8	3/16	0.188	0.212	0.194	0.281	0.250	0.241	0.099	0.089
7/16	7/32	0.219	0.252	0.232	0.328	0.297	0.287	0.114	0.104
1/2	1/4	0.250	0.291	0.70	0.375	0.344	0.334	0.130	0.120
5/8	5/16	0.312	0.371	0.347	0.469	0.469	0.456	0.164	0.148
3/4	3/8	0.375	0.450	0.425	0.562	0.562	0.549	0.196	0.180
7/8	1/2	0.500	0.530	0.502	0.656	0.656	0.642	0.227	0.211
1	9/16	0.562	0.609	0.579	0.750	0.750	0.734	0.260	0.240

Per ANSI/ASME B18.3

Note: Half Dog, Full Dog and Cone points are measured in overall length.